

CABLE DRUM TRAILER CD130 (EEC) HIGHWAY

Introduction.

The Trailer has been designed primarily for the purpose of transporting and unreeling of cable drums up to 5350Kgs weight only provided that the drum is of maximum width that the trailer will accept (see below).

The Trailer rides on two pneumatic road wheels with heavy duty hollow rubber suspension units. The position of the axle stubs is such that a nose weight is always present through the towing eye in both the laden and unladen conditions.

Loading of the cable drum is achieved by locating the drum and spindle tube in the sliding chevrons which can be locked in position. The hydraulic cylinders are then raised which leaves the drum free to unreel or be transported (see detailed procedure in operating instructions).

Note!

If Trailer is received with hydraulic rams raised then a weight is required to exhaust ram back to retracted position, after releasing hydraulic relief valve.

Highway Compliant Trailers built after October 2012 are European Whole Vehicle Type Approved (ECWVTA) to directive 2007/46/EC and relevant amendments and further embrace relevant conditions stated in Supply of Machinery (Safety) Directive 2006/42/EC.

Maximum S.WL Of Spindle = 5350Kgs At Drum Width 1470mm.

Cable Drum Trailer CD130 (BT No 4.) - Operation Sequence.

Warning - Ensure Safety Of Hands And Feet When Manhandling Trailer.

Before Use

Ensure locking plates (Item 2 – sheet PL 302) are correctly adjusted i.e. very slight binding fit achieved. If found to be loose the retaining nuts should be adjusted by the maintaining workshop.

Daily Spindle Check

Prior to loading Cable Drum, we advise that the spindle is located in the required lift chevron and with the slides in the elevated position, the operator is to push the spindle hard up to one side and then measure the gap between the end of the spindle and the inside face of the chevron on the opposite side. **This measurement should be no more than 18mm.**

To Load Cable Drum

1. If Trailer is to be unhitched from towing vehicle, the Trailer MUST be Supported by ensuring that the Jockey Wheel is lowered and clamped securely.
2. Remove Spindle locking bar clips (Item 3 PL302).
3. Now remove locking bars, thus the spindle bar can be removed. Take off one Spindle bar collar and slide the spindle bar into the drum. Make the spindle bar overhang equal each side and tighten up the spindle bar collar, using a 19mm A/F spanner supplied.
4. Raise under-run bumper (where applicable) and reverse trailer to drum until support chevrons contact spindle bar, if chevrons foul entry of spindle bar, pump up slides alternatively until clear.
5. Locate locking bars into original position and lock by inserting locking bar clips (Item 3 PL302).
6. Apply handbrake, lower rear prop stands and clamp securely.

To Raise Drum To Travelling Position.

7. Turn control valve lever (Item 15 PL200) to central position make sure pump release valve (Item 14 PL200) is fully closed by tightening clockwise. To raise drum, pump handle fore and aft until drum begins to raise.

If alternate movement of ram is required (i.e. to balance lift) move control lever to left or right to get individual ram control.

8. When rams are fully raised, swivel the locking plates (Item 2 – sheet PL 302) to line up with cut out notch in the fixed frame and slowly release hydraulic pressure via pump release valve until both plates are **FULLY SEATED** in the cut out notches, **NOW RETIGHTEN PUMP RELEASE VALVE.**
9. ONLY AFTER Trailer is hitched to towing vehicle, raise Jockey Wheel and rear prop stands to highest position, clamp securely and connect safety chain (where applicable). Couple up electrical lighting plug, brake couplings, ABS electrical susie and lower and fasten under-run bumper (where applicable).

Note!

Following “on site” cabling operations it is imperative to re-check that the locking plates (Item 2 – sheet PL 302) are fully seated in the cut out notches, and the pump release valve is closed **BEFORE** moving off.

To Lower Cable Drum

10. If the Trailer is to be unhitched from the towing vehicle, the Trailer MUST be supported by ensuring the Jockey Wheel is lowered and clamped securely.
11. Lower rear prop stands and clamp securely.
12. Recheck that hand pump release valve is still fully closed in accordance with instruction given in paragraph 8 above.
13. Pump up rams until locking plates (item 2 - sheet PL302) are fully clear of the cut out notch in the fixed frame, then swivel these plates through 180 degrees.
14. Slacken handpump release valve until drum begins to drop. Rate of descent of drum can be controlled by adjusting this valve to restrict oil flow back to hydraulic tank.

To Unload Cable Drum.

15. When drum is on ground, raise rear prop stands to highest position, clamp securely and connect safety chain clips (where applicable).
16. Raise rear underun bumper (where applicable).
17. Wedge drum to prevent it rolling, pull trailer from around drum, remove drum spindle locking collars and withdraw spindle from drum and replace into spindles cups on drum lifting frame.
18. Locate locking bars back into original position and lock by inserting locking bar clips (Item 3. PL23).

NOTE.

- *A) Rear underun bumper is fitted with a microswitch circuit through to the cab air pressure warning. The buzzer will therefore emit warning signal if the underun bar is not fully and safely locked in the horizontal position prior to travelling.
- *B) When the underun bumper is lifted to the vertical position (i.e. during unloading/loading operation) it is automatically and mechanically locked by means of spring loaded bolt. Manual disengagement of this bolt is to be carried out by the operator prior to lowering of bar.

OPERATOR WARNING.

1. DRUM LIFTING FRAME MUST BE FULLY RAISED AND LOCKED IN POSITION BEFORE TOWING.
2. DO NOT OVERLOAD DRUM SPINDLE (SEE PAGE PL194)
3. ALWAYS ENSURE DRUM IS FULLY LOCKED IN POSITION BY SPINDLE COLLARS PROVIDED 6 BEFORE TRAVELLING
4. THE TRAILER IS FITTED WITH A 2 LINE AIR AUTO ADJUSTING AIR BRAKING SYSTEM AND EQUIPPED WITH WABCO 2S-2M ABS. AT ANY TIME SHOULD THE GREEN ABS WARNING LIGHT STAY PERMANENTLY ILLUMINATED, THEN A FAULT HAS DEVELOPED IN THE SYSTEM. TO RECTIFY THE ABOVE EITHER CONTACT SEB, REFER TO THE WABCO BOOKLET AT THE REAR OF THE MANUAL OR CONTACT YOUR LOCAL WABCO SERVICE CENTRE.

OPERATOR MAINTENANCE.

1. Immediately upon receipt of your new Cable Drum Trailer and also whilst in service we recommend that regular checks be carried out on tyre pressure, and wheel nut tension. (Torque to 575Nm)
2. WEEKLY.
 - A) Check tyre pressure 125p.s.i.
 - B) Check for leaks on Hydraulic circuit
 - C) Check light bulbs.

* DENOTES BT. No.4 Trailer 6 Optional Fitment Only.

CABLE DRUM TRAILER CD130 (BT. NO.4) – MAINTENANCE.

1. Immediately upon receipt of your new cable drum trailer and also whilst in service we recommend that regular checks be carried out on tyre pressure, and wheel nut torque.
2. WEEKLY.
 - a) Check tyre pressure.
 - b) Check for leaks on hydraulic circuit.
 - c) Check light bulbs.
3. EVERY THREE MONTHS.
 - a) Check brake lining clearance and adjust if necessary.
 - b) Check wheel nut torque 575Nm.
 - c) Check tow eye fixing nut and retighten if necessary.
 - d) Check suspension unit retaining bolts and retighten if necessary.
 - e) Grease all pivot points on sub frame, tow unit, axle compensators etc.
 - f) Check everything in section 2.
 - *g) Grease underun bumper pivot (nipple located behind plastic end cap.)
 - h) Check setting of load sense valve ó Refer to Data Plate adjacent to valve.
 - i) Examine top gland nut and piston in drum lift hydraulic cylinder for possible ingress of dirt, and clean where necessary.

RECOMMENDED OILS AND GREASES.

Hydraulic Oil.

VG 68

Lubrication Grease.

Ovoline all purpose grease (or equivalent).

HYDRAULIC HANDPUMP MAINTENANCE.

The only maintenance required is to occasionally check hydraulic oil level. However if after a period of time, seals etc. become worn a reconditioning kit is available.

* BT. No. 4 Trailer ó Optional Fitment only.

When replacing tyres the following designations are acceptable -

Size - 11R22.5

Load index rating - 148/145

Speed index - L or M

Brakes

It is important that operators develop a schedule for periodic cleaning, inspection, adjustment and lubrication of brake components. This will provide the prevention rather than cure of brake problems. Adjustment of brakes should be carried out as frequently as required, in order to maintain the original safety standard. Slack adjuster travel and uniform lining clearance must be maintained.

At regular intervals, brake drums should be removed and linings checked for wear. The linings must not be allowed to wear down beyond the wear line, or to the rivets. After fitting new or re-lined shoes, always fit new return springs. Each time the hubs are removed for brake inspection, check the following parts for wear:

1. All hub components.
2. Grease seals. (It is recommended that new seals are fitted)
3. Bearing cups, cones & rollers.
4. Brake anchor pins and location holes.
5. Cam rollers and retaining pins.
6. Wheel studs and nuts.
7. Check brake drum for cracks, scoring or any form of deterioration.

Prior to re-assembly, the following parts should be coated with 'axle grease' or equivalent product:

1. Cam roller location diameters and journals.
2. Anchor pin location holes in brake shoes.
3. Brake Anchor Brackets (spiders) camshaft bores.
4. Cam head/roller contact

Note: BRAKE LININGS SHOULD BE REPLACED AS A COMPLETE AXLE SET!

Once new lining have been fitted, braking performance will be reduced until the new lining have 'bedded in'. This can take up to 1000 km depending on operating conditions. Therefore it is recommended that linings are replaced well before critical brake performance inspections such as MOT tests etc. Check with manufacturer of your slack adjusters for any adjustment that is required.

Slack adjusters should be installed and serviced in line with their manufacturer's guidelines.

Changing brake shoes

All Granning 860 series axles use Quick-Fit brake shoes, please ensure the correct replacement components are used.

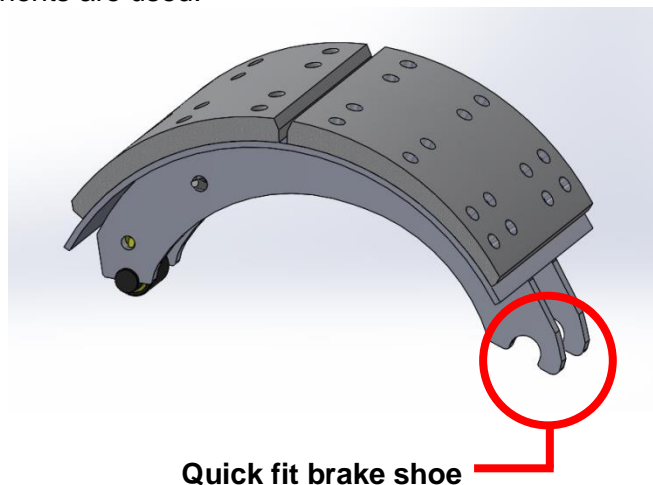

Removal of quick fit brake shoes

Removal of Brake Shoes from 860 (External drum) Series axles does not require the removal of the Hub, as the drum can be pulled over this assembly without disturbing it. The below images have the hub and drum removed for clarity.

Be careful when removing wheel assembly as the drum may come off with the wheel and then fall when clear of hub and wheel.

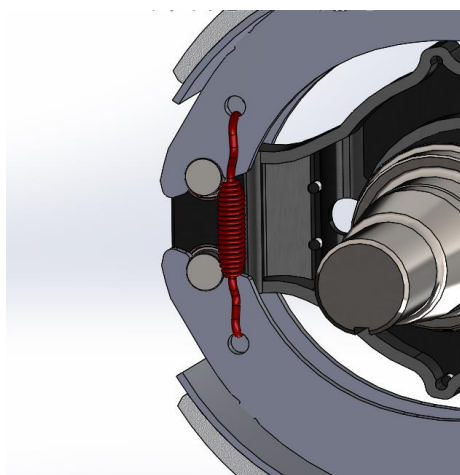

Remove the two brake shoe tensioning springs, taking care not to release them under tension.

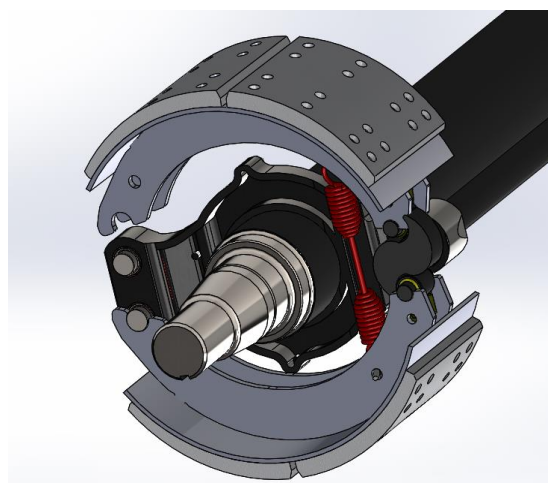

Lift off both brake shoes from the brake anchor pin, and allow them to close around the axle.

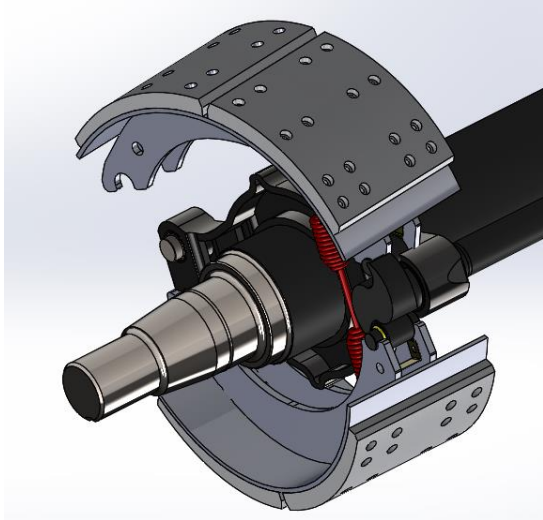

Push the lower shoe down, and pull the shoe outwards.

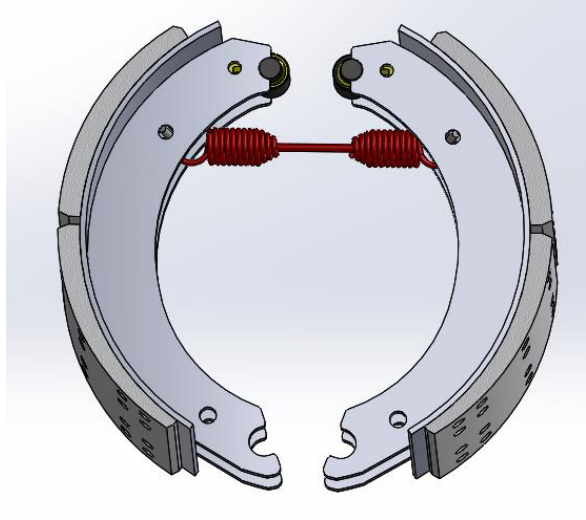

Finally remove the return springs and the anchor bars.

Fitting of a new set of brake shoes is the reversal of the above procedure.

CABLE DRUM TRAILER CD130 (BT. No.4.) – TECHNICAL DATA.

LIFTING SYSTEM.

Single line system from hand pump to hydraulic drum lift cylinders with flow control valve situated above hand pump.

Pressure required to raise drum ó 1570p.s.i. (107 bar).

NOTE.

The pressure required to lift the cylinders off their locking plates is the same as for above but then oil is exhausted from the cylinders back in to the tank by gravity feed exerted by the drum weight during lowering operation.

FLOW.

When operating the system described above the flow of the hydraulic oil may be variably controlled by means of the pressure release valve on the front of the hand pump.

HAND PUMP DATA.

- | | |
|---|-----------------------------|
| 1. Capacity of Tank. | 3.41 ltrs (6 pints) approx. |
| 2. Delivery/Single stroke lever | 7.137cm (0.435cu ins.) |
| 3. Working volume of fluid to operate system. | 2.273ltrs (4 pints). |
| 4. Pump relief pressure setting. | 2500p.s.i. (170 bar). |

CYLINDER DATA.

- | | |
|-----------------|------------------------------------|
| 1. Bore | 57mm (2¼ö) diameter single acting. |
| 2. Rod diameter | 38mm diameter. |
| 3. Stroke | 368mm ó 14.5ö. |

SUSPENSION DATA. (Hollow Rubber Spring Type).

- | | |
|-------------------------------|--------------------|
| Maximum load per spring. | 3150kg. (6,942lbs) |
| Maximum deflection per spring | 70mm (2.75ö) |

RECOMMENDED OILS AND GREASES.

Hydraulic Oil = Class VG68²

Lubricating Grease = Ovoline 75 General Purpose (or equivalent)

WHEEL NUTS.

Size = 7/8ø Torque = 400lbf./ft. (stud mount wheel)

Size = M.22 Torque = 400-500ft.lb (spigot mount wheel).

TYRE PRESSURE. = 8.5BAR

TRAILER CHASSIS NUMBER MUST ALWAYS BE QUOTED WHEN ORDERING SPARES

PART'S LIST

ITEM	DESCRIPTION
1	WHEELS
2	TYRES
3	JOCKEY WHEEL
4	PROP STANDS
5	WHEEL ARM
6	SLIDE LIFT
7	HYDRAULIC SYSTEM
8	BRAKE SYSTEM
9	ELECTRICAL SYSTEM
10	SPINDLE
11	SPINDLE COLLAR
12	UNDER RUN BUMPER IF FITTED
13	PUMP RELEASE VALVE
14	CONTROL VALVE LEVER
15	ABS ECU IF FITTED
16	ABS DIAGNOSTIC SOCKET IF FITTED
17	ABS ELECTRICAL SUSIE IF FITTED

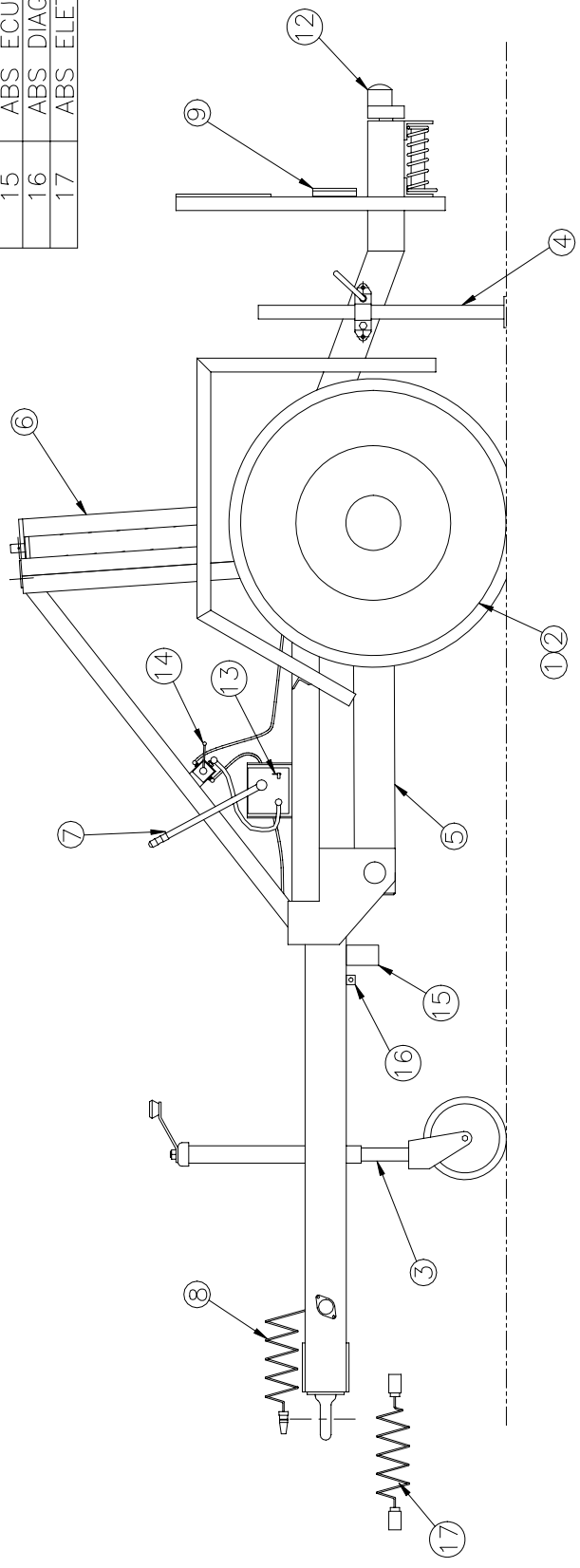
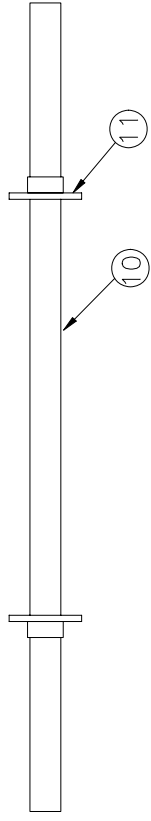

TRAILER CHASSIS NUMBER MUST ALWAYS BE QUOTED WHEN ORDERING SPARES

PART'S LIST

ITEM	DESCRIPTION
1	HYDRAULIC RAM
2	RAM LOCK PLATE – MAIN LOCK
3	LOCKING BAR CLIP/CHAIN
4	HYDRAULIC RAM LOCK NUT
5	SLIDE RETAINER PLATES
6	SLIDE RETAINER PLATES & ROLLER
7	HYDRAULIC RAM PIVOT PIN
8	SPINDLE LOCKING BAR
9	SECONDARY LOCK – BT ONLY (09/14)

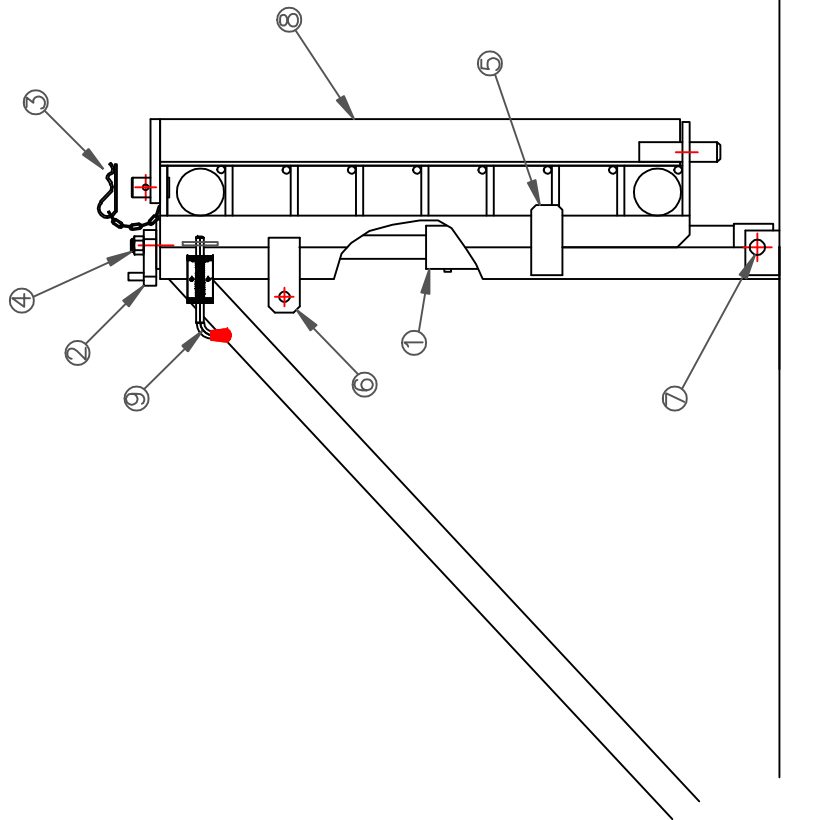

TRAILER CHASSIS NUMBER MUST ALWAYS BE QUOTED WHEN ORDERING SPARES

PART'S LIST

ITEM	DESCRIPTION
1	HYDRAULIC PUMP
2	CONTROL VALVE
3	PUMP RELEASE VALVE
4	MAIN FEED HOSE
5	SHORT RAM HOSE
6	LONG RAM HOSE
7	HYDRAULIC RAM

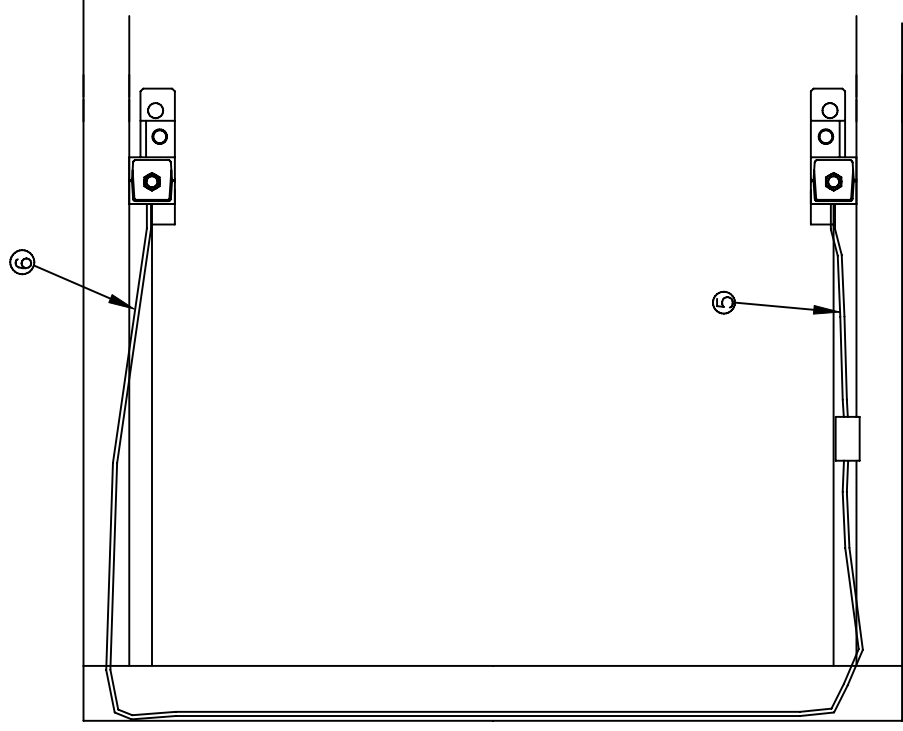
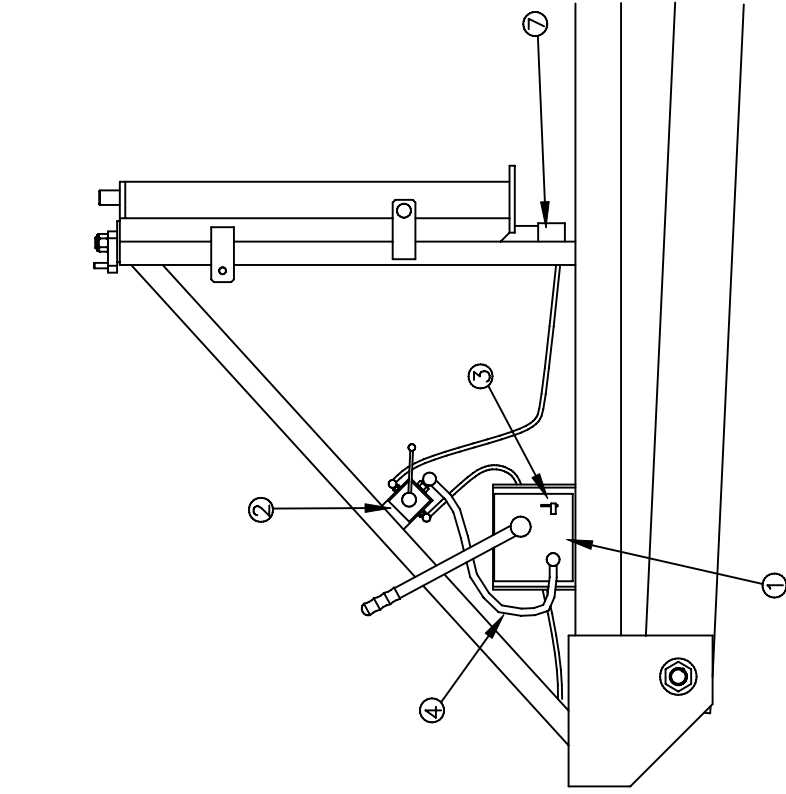

TRAILER CHASSIS NUMBER MUST ALWAYS BE QUOTED WHEN ORDERING SPARES

PART'S LIST

ITEM	DESCRIPTION	REF
1	PUMP & TANK COMPLETE	HP2 BT
2	PUMP FRONT ONLY	HP2 LT
3	PUMP SEAL KIT	0102/SK
4	HANDLE & GRIP	0101/08

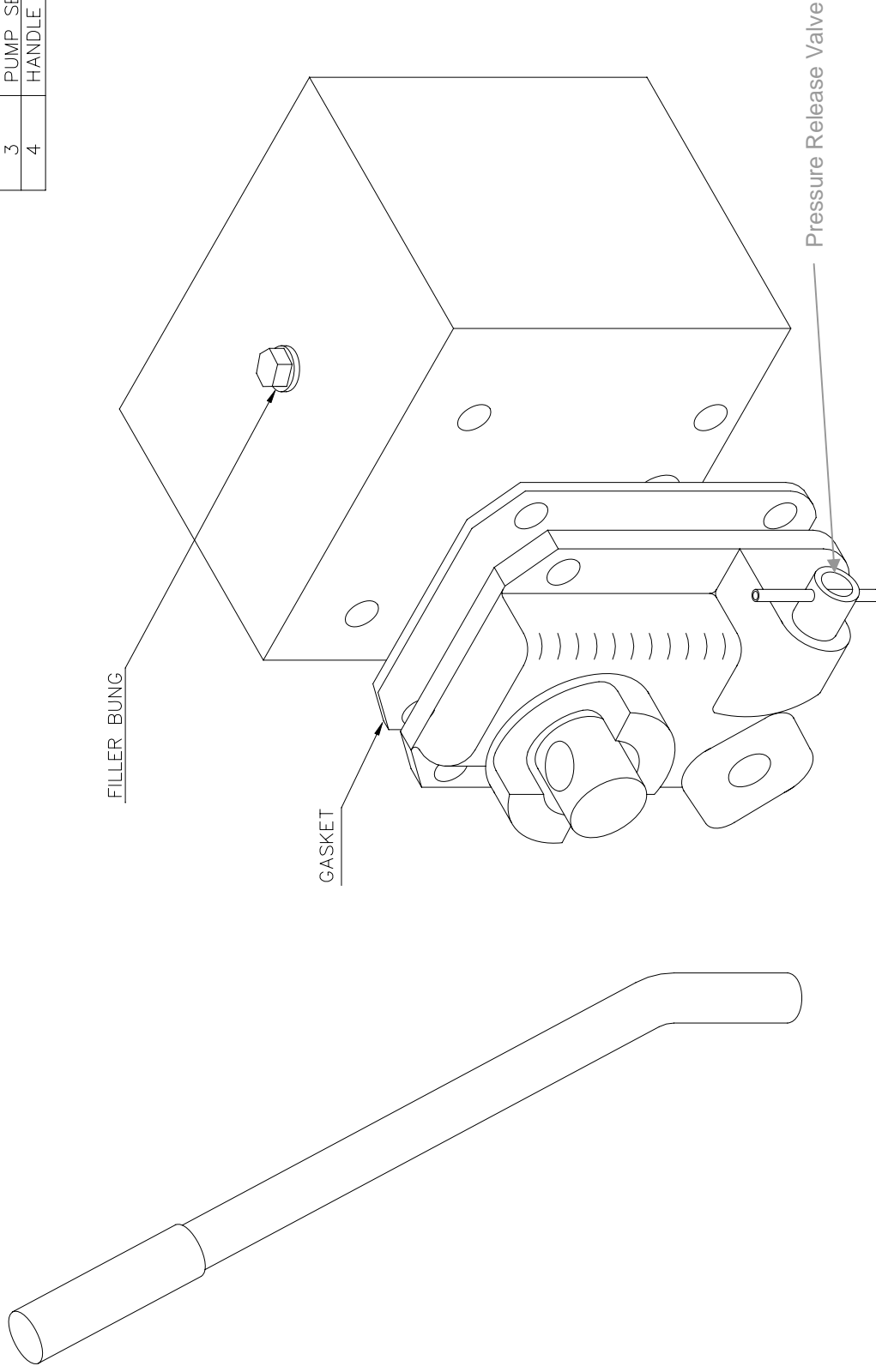

HP2 HANDPUMP/RESERVIOR ASSEMBLY

SHEET NO :- PL 148

TRAILER CHASSIS NUMBER MUST ALWAYS BE QUOTED WHEN ORDERING SPARES

PART'S LIST

ITEM	DESCRIPTION
1	PISTON SEAL
2	WIPER SEAL
3	GLAND SEAL

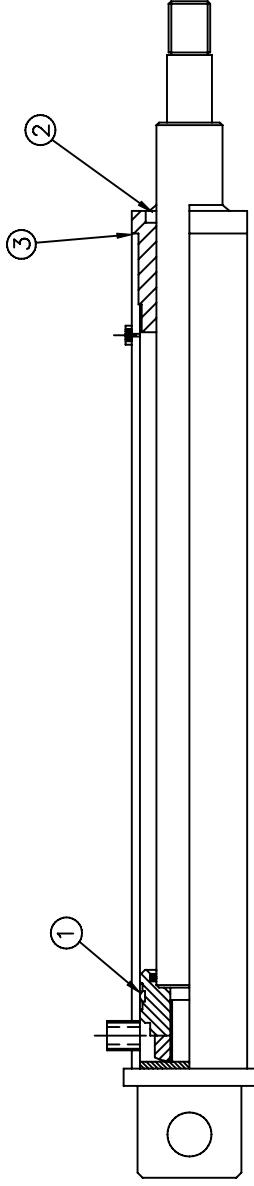

TRAILER CHASSIS NUMBER MUST ALWAYS BE QUOTED WHEN ORDERING SPARES

PART'S LIST

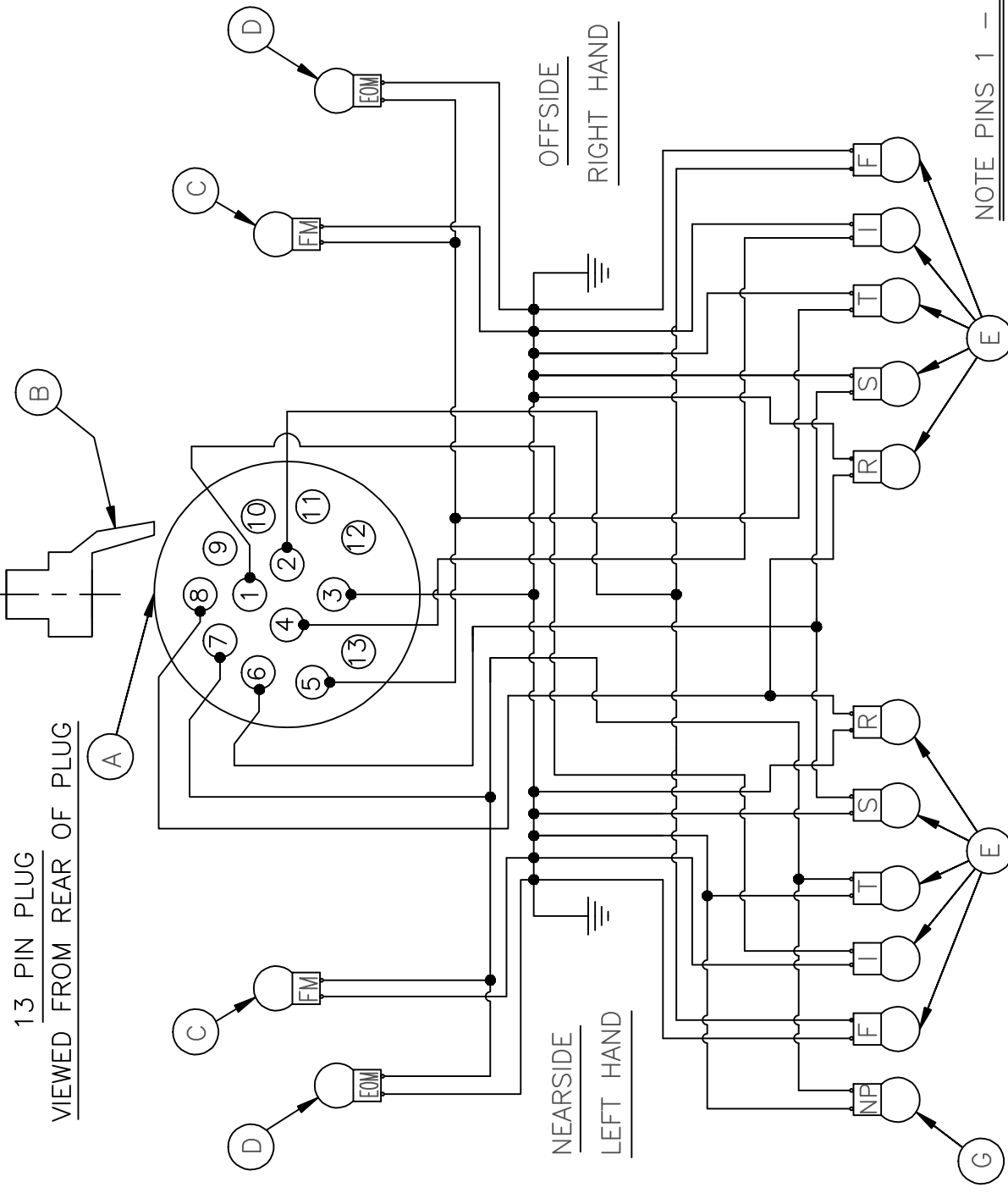

ITEM	DESCRIPTION
A	13 PIN PLUG
B	OPTIONAL 13 PIN-7 PIN CONVERTER
C	FRONT MARKER WHERE FITTED
D	END OUTLINE MARKER
E	REAR LIGHT CLUSTER
G	NUMBER PLATE LIGHT

13 PIN PLUG COLOUR CODE	
1	YELLOW - N/S INDIC
2	BLUE - FOG
3	WHITE - EARTH
4	GREEN - O/S INDIC
5	BROWN - O/S SIDE
6	RED - STOP
7	BLACK - N/S SIDE &
8	PINK - REVERSE
9	ORANGE - BATTERY SWIT
10	GREY - BATT IGN SWIT
11	WHITE/BLACK - EARTH F
12	WHITE/BLUE - RESE
13	WHITE/RED - EARTH F

NOTE PINS 1 - 8 ONLY USED ON TRAILER LIC

ELECTRICAL SYSTEM (TO ISO 11446)

SHEET No:- PL1050

TRAILER CHASSIS NUMBER MUST ALWAYS BE QUOTED WHEN ORDERING SPARES

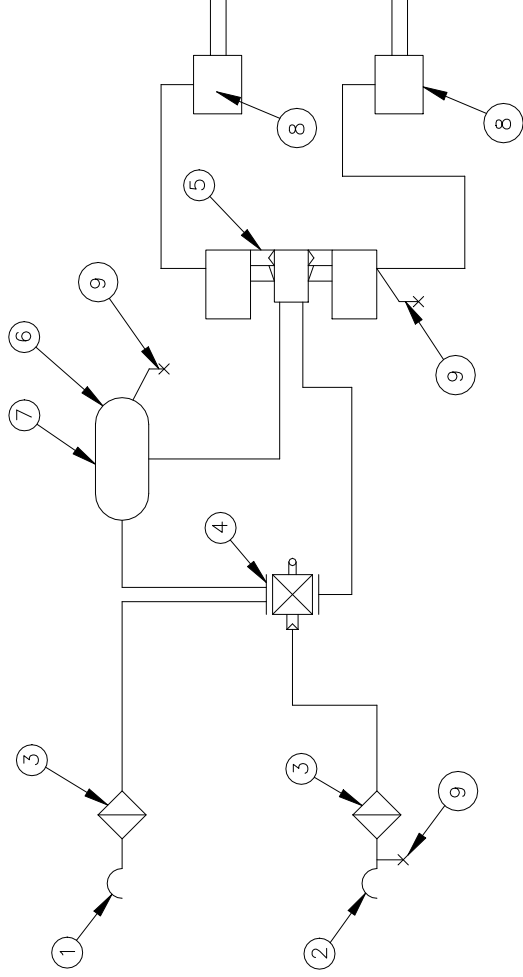

PART'S LIST

ITEM	DESCRIPTION
1	COUPLING (EMERGENCY)
2	COUPLING (SERVICE)
3	AIR FILTER
4	LSV/RE VALVE
5	ABS ECU
6	AIR RESERVOIR
7	DRAIN VALVE
8	AIR ACTUATORS
9	TEST POINT

TRAILER CHASSIS NUMBER MUST ALWAYS BE QUOTED WHEN ORDERING SPARES

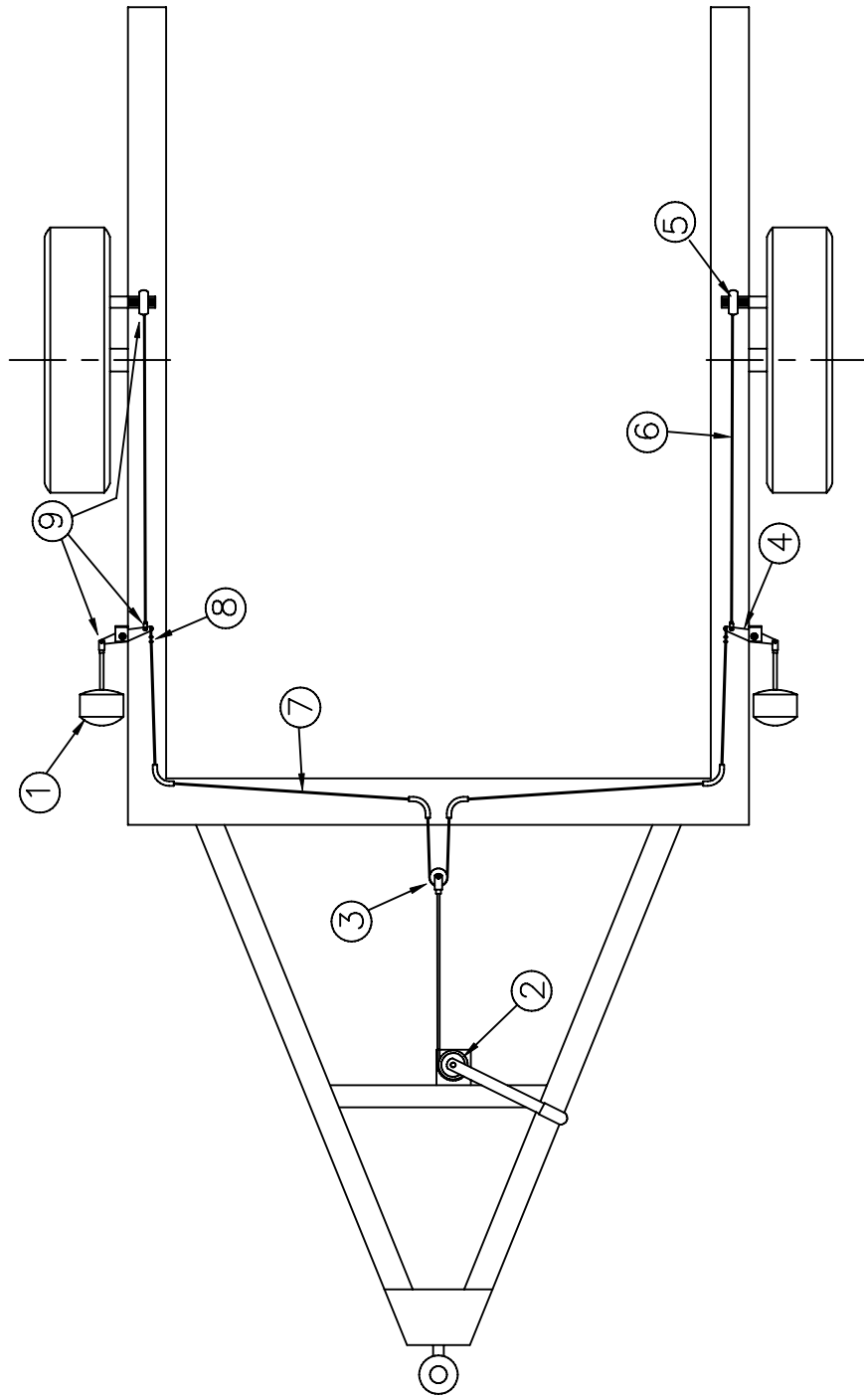

PART'S LIST	
ITEM	DESCRIPTION
1	BRAKE ACTUATOR
2	HAND PARK BRAKE
3	PULLEY
4	TRANSFER LEVER
5	SLACK ADJUSTER
6	BRAKE ROD
7	WIRE ROPE
8	ROPE GRIPS
9	CLEVIS CONNECTORS

TRAILER CHASSIS NUMBER MUST ALWAYS BE QUOTED WHEN ORDERING SPARES

PARTS LIST

ITEM	DESCRIPTION
1	HUB & BRAKE ASSY
2	SUSPENSION UNIT
3	PIVOT PIN
4	PIVOT PIN BUSH
5	PIVOT PIN BOSS
6	PIVOT PIN WASHER
7	PIVOT PIN NUT
8	GRUB SCREW

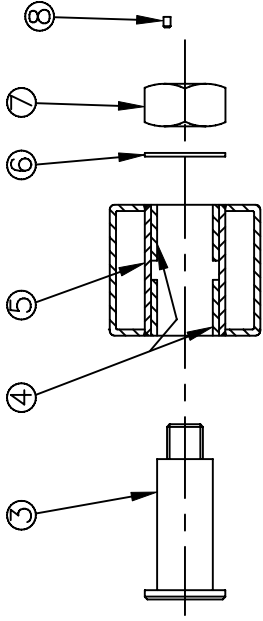

SECTION 'A'-'A'

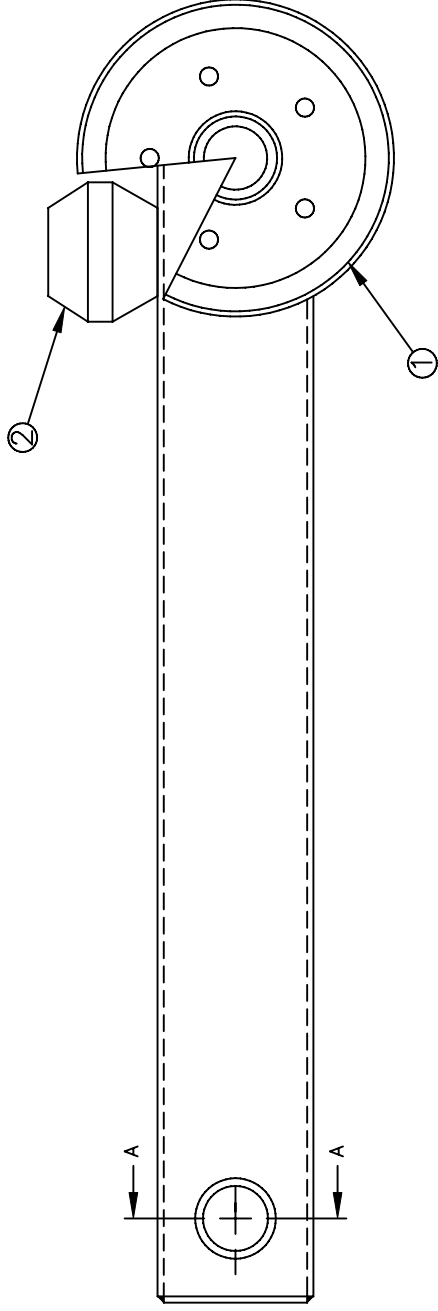

TRAILER CHASSIS NUMBER MUST ALWAYS BE QUOTED WHEN ORDERING SPARES

PART'S LIST

ITEM	DESCRIPTION
1	STUB AXLE
2	WHEEL STUD
3	WHEEL NUT
4	HUB
5	BACK PLATE
6	INNER BEARING
7	OUTER BEARING
8	OIL SEAL
9	BRAKE SHOES
10	BRAKE DRUM
11	HUB CAP
12	AXLE NUT
13	AXLE WASHER
14	SPLIT PIN
15	CAM SHAFT
16	A.B.S. SENSOR UNIT *

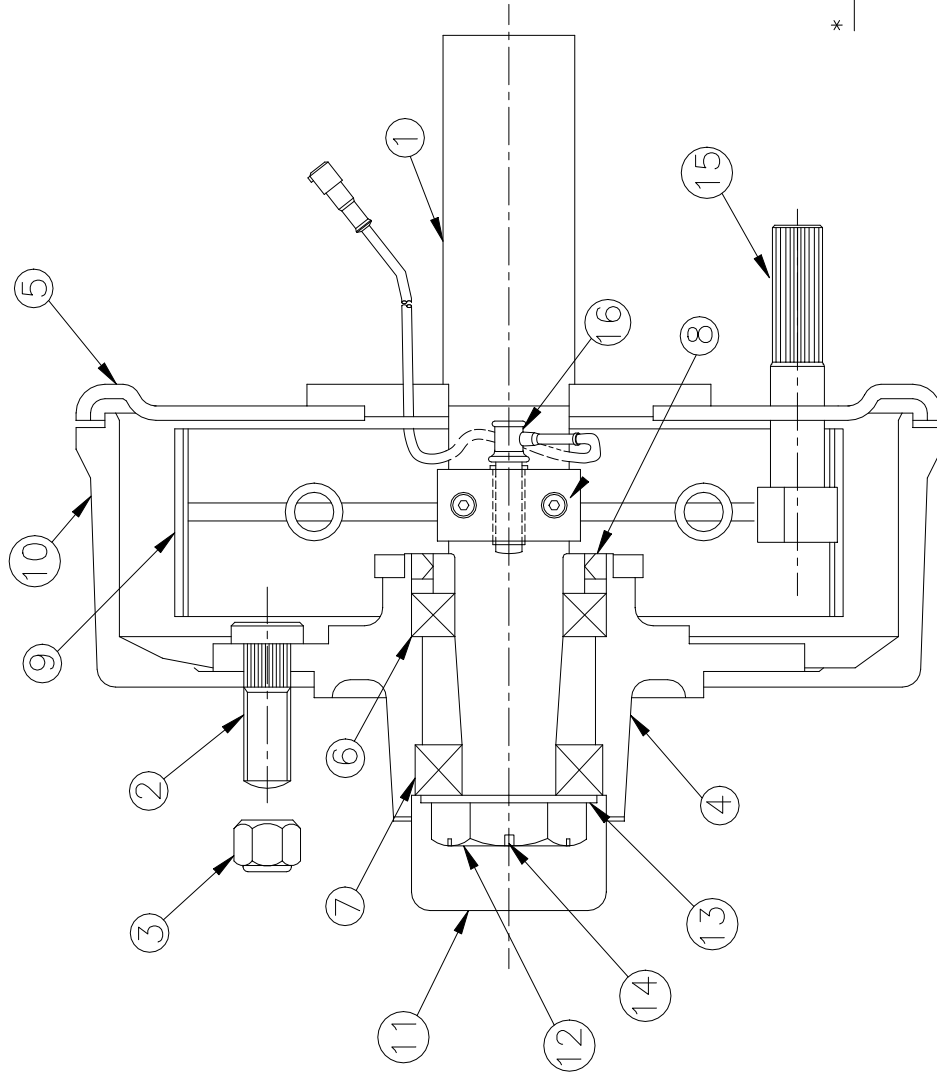

* TO SET SENSOR FIRMLY PUSH HEAD OF SENSOR UNIT TO ENGAGE SENSOR NOSE AGAINST POLE WHEEL
DO NOT USE POINTED INSTRUMENT